



Lighting
Technologies

DIALLEO

LED

FAST
SIMPLE
EFFICIENT

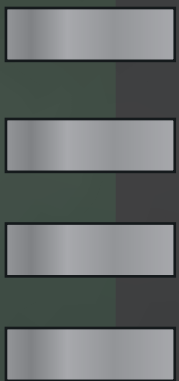

INDUSTRIAL

Lighting

 INDUSTRIAL

DIALLEO LED

A new innovative and different series of continuous IP65 LED light system.

DIALLEO LED is the perfect solution to change from conventional continuous line system to LED.



The lighting units together with the pre wired trunking reduce the time of installation and maintenance.

Designed to be used for car parks and production halls to warehouses and logistic areas.

For industrial applications, the demands has to meet high requirements.



Lighting is more and more playing a critical role when it comes to productivity and safety.

To meet these current market needs we have developed continuous line system DIALLEO LED.

A system which combines high efficacy and safety with simple installation and convenient maintenance.

CAPABILITIES

It has a variety of optics, color temperatures and powers to suit all lighting needs.

**DIALLED
LED**

High quality IP65 continuous line system

**35
50 W
70**

CRI 80

**IK 02
IK 08**

IP 65

**4000K
5000K**

**Up to
165 lm/W**

**Click
system**

Due to the unique swivel click system light units and blind covers can be mounted without any tools. Installation of any unit takes only about 10 seconds.

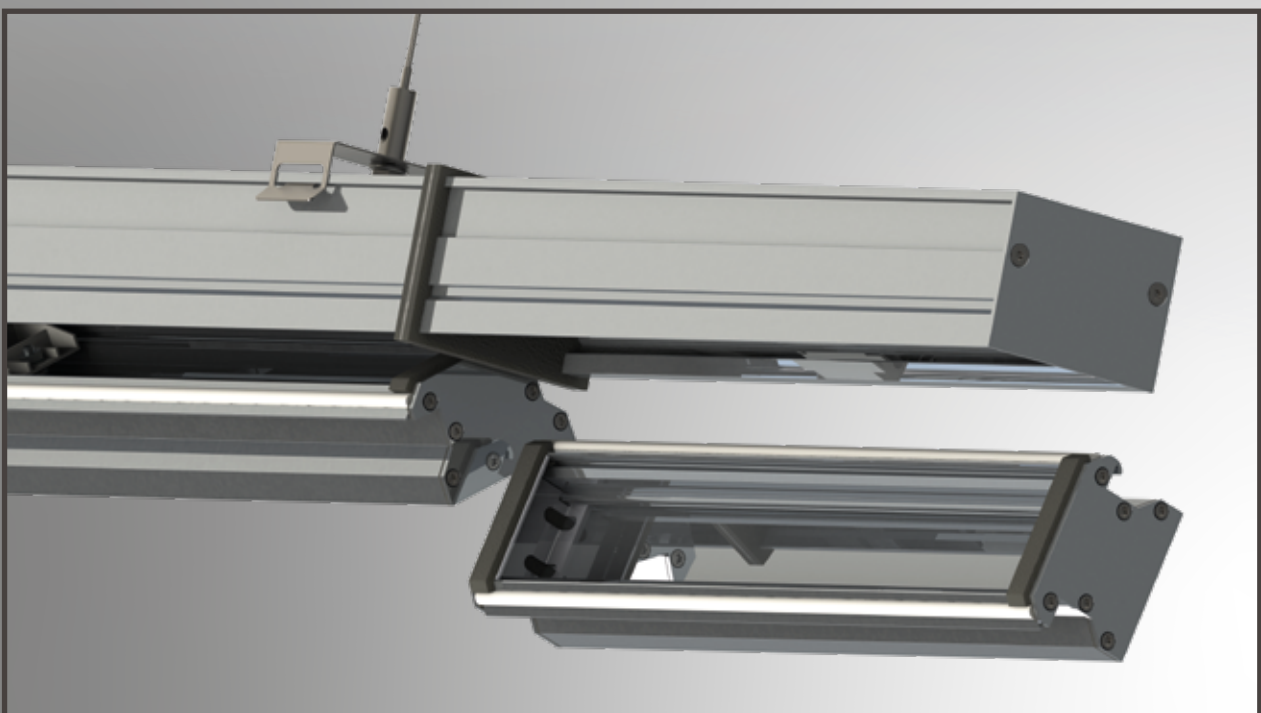

STRUCTURE

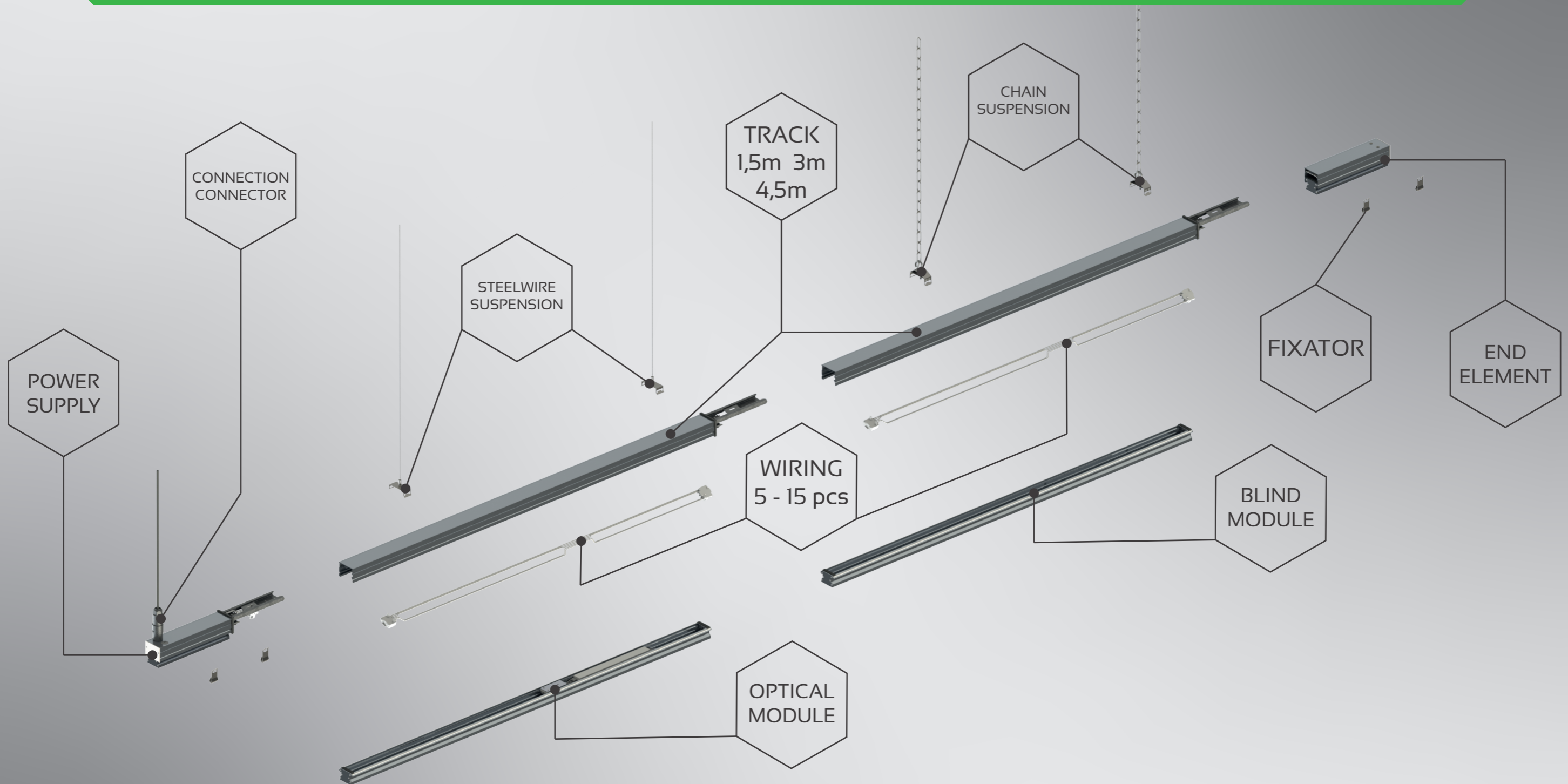

Using components from leading world manufacturers (SAMSUNG LEDs, VOSSLOH-SCHWABE driver) and outstanding engineering solutions allowed us to achieve highest luminous efficacy up to 165 lm/W.



OPTICS

D30 (NB)



Narrow beam lighting distribution for high rack areas in logistics industries

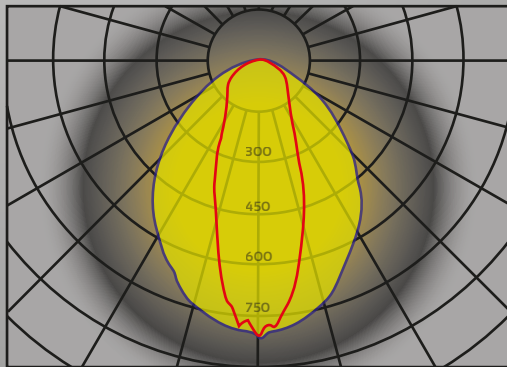

D60 (MB)



Medium beam lighting distribution among others to replace high-bay luminaires

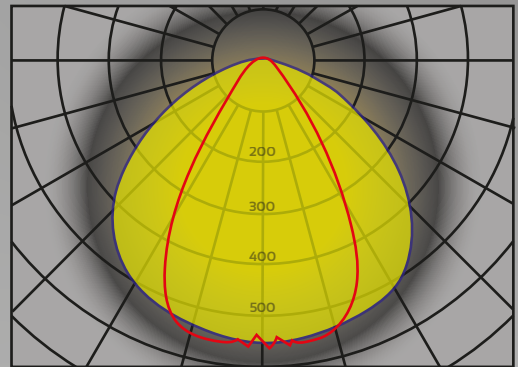

D90 (OPAL)

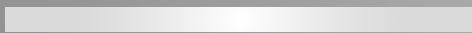

Opal for standard applications

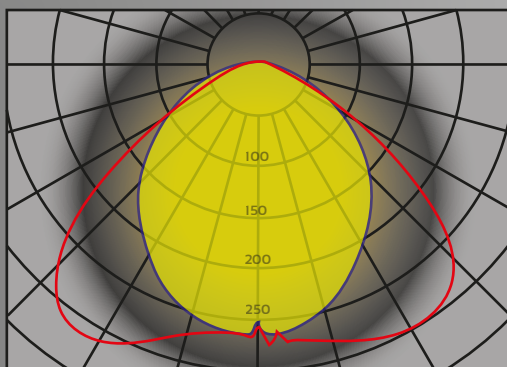

D120 (UWB)



Ultra-wide lighting distribution for general lighting and wide aisle

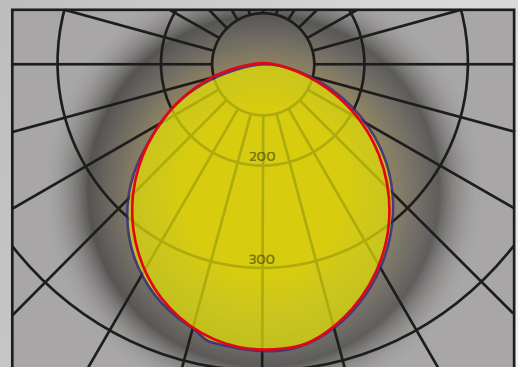

FLEXIBLE IN WIRES

5 wires

1	L1	MAIN POWER
2	L2	
3	L3	
4	PE	
5	N	

7 wires

1	L1	MAIN POWER
2	L2	
3	L3	
4	PE	
5	N	
6	+	DALI, 1-10V, EM
7	-	



9 wires

1	L1	MAIN POWER
2	L2	
3	L3	
4	PE	
5	N	
6	+	DALI, 1-10V, TELEMANDO
7	-	
8	+	EM
9	-	

11 wires

1	L1	MAIN POWER
2	L2	
3	L3	
4	PE	
5	N	
6	L1	DALI, 1-10V
7	L2	
8	+	EM
9	-	
10		TELEMANDO
11		

15 wires

1	L1	MAIN POWER
2	L2	
3	L3	
4	PE	
5	N	
6	+	216 VDC POWER FROM CENTRAL BATTERY
7	-	
8	+	DALI, 1-10V
9	-	
10	L1	FROM GENERATOR
11	L2	
12	L3	
13	PE	
14	N	
15		SPARE



ACCESSORIES

STEELWIRE SUSPENSION

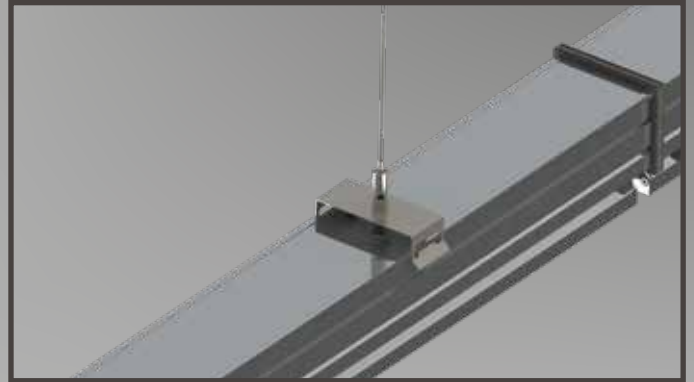

CHAIN SUSPENSION

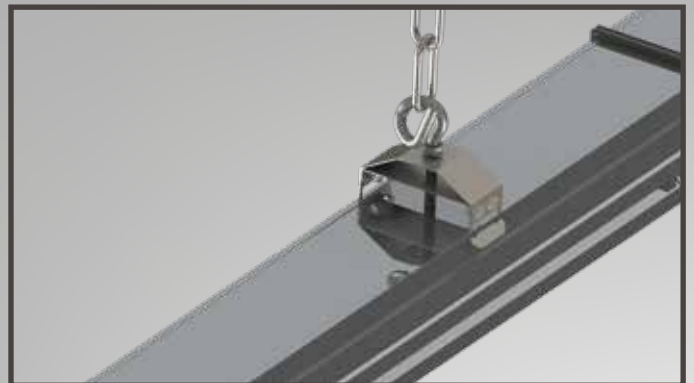

TECHNICAL INFORMATION

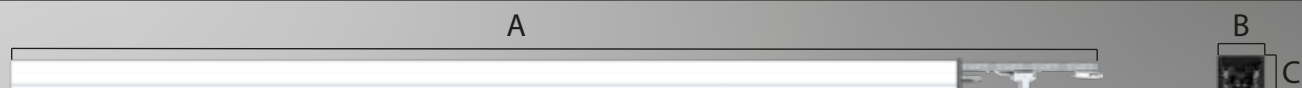

Code.	Name	A, mm	B, mm	C, mm
1997030490	DIALLEO LED TRACK 7X2,5 1500MM AL (U) /E/	1737	73	57
1997030500	DIALLEO LED TRACK 7X2,5 3000MM AL (U) /E/	3249	73	57
1997030460	DIALLEO LED TRACK 5X2,5 1500MM AL (U) /E/	1737	73	57
1997030470	DIALLEO LED TRACK 5X2,5 3000MM AL (U) /E/	3249	73	57

Code.	Name	A, mm	B, mm	C, mm	Installation dimensions, mm
1997030330	DIALLEO LED 35 (PMMA/AL) D90 4000K (U) /E/	1504	62	43	1505
1997035590	DIALLEO LED 35 (PMMA/AL) D60 4000K (U) /E/	1504	62	43	1505
1997030370	DIALLEO LED 50 (PMMA/AL) D60 4000K (U) /E/	1504	62	43	1505
1997030380	DIALLEO LED 50 (PMMA/AL) D90 4000K (U) /E/	1504	62	43	1505
1997030420	DIALLEO LED 70 (PMMA/AL) D60 4000K (U) /E/	1504	62	43	1505
1997030430	DIALLEO LED 70 (PMMA/AL) D90 4000K (U) /E/	1504	62	43	1505

Code.	Name	lm	W	lm/W	kg	PFC
1997030330	DIALLEO LED 35 (PMMA/AL) D90 4000K (U) /E/	5250	37	142	2,4	≥0,95
1997035590	DIALLEO LED 35 (PMMA/AL) D60 4000K (U) /E/	6150	37	166	2,4	≥0,95
1997030370	DIALLEO LED 50 (PMMA/AL) D60 4000K (U) /E/	8650	52	166	2,4	≥0,95
1997030380	DIALLEO LED 50 (PMMA/AL) D90 4000K (U) /E/	7450	52	143	2,4	≥0,95
1997030420	DIALLEO LED 70 (PMMA/AL) D60 4000K (U) /E/	11900	73,5	162	2,4	≥0,95
1997030430	DIALLEO LED 70 (PMMA/AL) D90 4000K (U) /E/	10220	73,5	139	2,4	≥0,95

Length of line (meter):	Light units (1,512 meter)	Trunking section: 1,512 meter (2 unit)	Trunking section: 3,024 meter (2 unit)	Mounting brackets	Power/connection set (including end cap) 0,3 meter	End unit (including end cap) 0,3 meter
3,024	2		1	2	1	1
4,536	3	1	1	2	1	1
6,048	4		2	4	1	1
7,560	5	1	2	4	1	1
9,072	6		3	5	1	1
10,584	7	1	3	6	1	1
12,096	8		4	6	1	1
13,608	9	1	4	7	1	1
15,120	10		5	8	1	1

CONTACT US



Lighting Technologies Europe GmbH
Address: Fraunhofer Strasse 7
85737 Ismaning, Germany
T: +49 (0) 89 550 59 8611
E: eu.sales@LTcompany.com

Lighting Technologies Europe GmbH
Address: Alte Duisburger Strasse 11
47119 Duisburg, Germany
T: +49(0) 173 637 4552 / +31 (0) 613 724 900
E: EU.Sales@LTcompany.com

Manufacture: Ltd «Company «Vitava»
Address: Etc. Enthusiasts, 8
Slavutyh, Kiev Region, Ukraine
T: +38 (044) 585 47 88
E: info@slv.LTcompany.com

Lighting Technologies Ukraine
Address: St. Vladimir Sosyura
602090 Kiev, Ukraine
T: +38 (044) 585 47 88
E: info@kiev.LTcompany.com

Alexandru Panico
Representative Romania,
Hungary & Bulgaria
T: +40 746 27 4556
E: A.Panico@LTcompany.com